



As secure as it is good-looking:
main entrance door hardware
in bronze



The Celestial Disc of Nebra is considered to be the world's oldest rendition of the heavens – and, like the main entrance door hardware and accessories handles in this brochure, it too was made of precious bronze. The timeless beauty of this material has inspired FSB to produce fittings in bronze that are setting design accents in contemporary architecture.

Material and Finishes	4
Use and Care	6
Oval + Round Pull Handle Series	7
Our Bronze Range	
Oval Pull Handles	8
Oval + Round ht Welded	14
Round Pull Handles	16
Doorknobs	22
Handle and Rose Assemblies	24
Armoured Roses	25
Flush Armoured Roses	26
Armoured Rose for Narrow- Frame Doors	27
Security Hardware	28
Intercom and Bell-Push Plates	30
Letter Plate	32
Door Stop	33
Numbers and Letters	34
Standards and Security Classes	36
Fixing Details	37

Material and Finishes

Like brass, bronze is not a natural product but the upshot of human invention. Bronze is an alloy of copper and tin (hence the expression ‘tin bronze’, which is still current).

The specific properties of bronze underpin a great many technical developments – both in the distant past and in the hi-tech present. It is with good reason that an entire period of human history is named after this metal – the Bronze Age. Copper was man’s only working metal for a very long time before the art of alloying various metals was discovered and hence application options were extended and enhanced. Learning how to combine copper and tin to form an alloy, bronze, was an achievement on a par with the feats of industrialisation. Whereas pure copper is comparatively soft, the tin in bronze lends it great strength and hardness. Bronze is also very resistant to corrosion and wear, moreover.

A very distinctive metal

What, in a very literal sense, most visibly distinguishes bronze is revealed by years of use. With time, bronze hardware acquires added appeal. The patina that develops really brings out the material’s aesthetic charm and that of lever handles made of it. Polished bronze fittings darken through the effects of the atmosphere and environment. Patina should not be thought of as being a material blemish here. Rather, it bears testimony to credible ageing and the benefits of change.

Bronze is a material that is used, not used up, one that has been recovered and broken down into its recyclable constituents since time immemorial. And it is not just in facilitating the economical use of resources that bronze has affinities with “wabi-sabi”, the traditional Japanese system of values and aesthetics.

Factors such as its natural ageing process, the beauty this gives rise to, its earthy colouring and its warmly sensuous emanations imbue bronze with a quality that lends lever handles made of the material uncommonly beautifying powers.

The tradition of bronze in architecture

By supplying a selection of its lever handle models in bronze, FSB is reviving a tradition that was indefensibly consigned to oblivion during the heyday of post-modern architecture. Not only is bronze a material that is intricately tied up with the history of human civilisation, it also excels by virtue of material qualities and of haptic and visual properties that from a very early stage led to its being favoured for the making of objects, fixtures and fittings in architecture – lever and pull handles included.

Bronze was already playing a major part in architecture back in antiquity, in the Middle Ages and during the Renaissance period. Doors and portals on prestigious buildings still impressively bear witness to the momentous nature of this material today.

Many architects cherish the noble character of bronze – and were doing so long before it was rediscovered for prestigious structures in the new Berlin. The German bronze tradition goes back a long way. In the mid-19th century, Samuel Abraham Loevy set up a bronze foundry of the same name and established it as a makers of “high-quality fittings in gunmetal and yellow metal” as bronze and brass were originally referred to. Until it was expropriated by the National Socialists in 1939, the S. A. Loevy company worked for architects such as Peter Behrens or Heinrich Straumer and produced hardware, fixtures and fittings for a great many award-winning public building projects.



7305



7615



7625

We supply door and window hardware plus accessories in bronze in the following finishes:

FSB 7305
Bronze Polished Waxed

FSB 7615
Bronze Bright Patinated Waxed

FSB 7625
Bronze Dark Patinated Waxed

There may be slight colour variations between batches where artificial aged bronze in particular is concerned. Far from being a quality defect, this phenomenon is rooted in the nature of the material and the chemical ageing process, which may give rise to slightly varying colour shades depending on the climatic or production conditions involved.

Such discrepancies are evened out, however, from the moment the hardware is subjected to regular use and a natural patina is formed.

Polished Bronze

Hardware with finish 7305 is polished and acquires a subtly natural-looking sheen as a result. Surfaces patinate in a natural manner in the course of time.

Artificially Aged Bronze

Fittings incorporating finishes 7615 and 7625 are pre-treated adopting a method specially developed by FSB. An immersion bath for cupriferous metals replicates the natural ageing process of the material. Artificial ageing yields a typical bronze patina that is every bit as impressive as that brought about by environmental influences.

A final coating of wax at the works protects both finishes against the aforementioned external influences, which would discolour untreated bronze surfaces. The wax used can be effortlessly removed with a proprietary cleanser and is ecologically sound.

Further materials and finishes

Our door and window hardware is also available in further attractive materials such as Stainless steel, Aluminium, AluGrey® and Brass as well as in other finishes of course. We will be pleased to send you the latest FSB Manual setting out our entire product range at no cost.

Use and Care

Areas of application

After the years of the stainless steel boom and a soberly functional formal vocabulary in architecture, the desire for a new material with a fresh appearance is making itself heard more and more. Bronze fittings suggest themselves for settings in which lambent shades predominate or nuanced design accents are to be set.

Corrosion control

For aesthetic reasons, we would not recommend holding time back artificially. FSB will, if expressly requested to do so, supply anyone hell bent on cocking a snook at the forces of nature all the same with bronze door levers sporting a lacquer finish. We would, however, emphatically advise against such a choice, since the coating involved detracts from the natural patina effect typical of the material. Lacquered bronze fittings lose their sheen, moreover, as soon as the lacquer is damaged and intercrystalline corrosion sets in.

Surface hygiene

Items of daily and regular use are undeniably popular habitats for bacteria and germs. This is inevitably also the case with lever handles – especially in public buildings, where they are subject to greater use. Some competitors claim that certain materials kill germs more effectively than others. But in our opinion this only (measurably) holds true under laboratory conditions. Whether a given host material destroys bacteria in 24 hours or in 72 is academic really, since doors tend to be in fairly regular use anyway. You would have to take remedial action every time a door were negotiated to eliminate germs altogether.

Pull Handle Series Oval + Round

FSB has now added a fully-fledged alternative to its traditional tubular pull-handle range with a comprehensive collection of oval designs. Both sets of designs can be fixed in a variety of ways.

Adopting the formula 'diagonal + oval = ideal gripping' espoused by FSB reduces the amount of effort required to take hold of and operate the handles on doors. The oval styling offers the market a new gripping quality for eye and hand which FSB has had copyright protected.

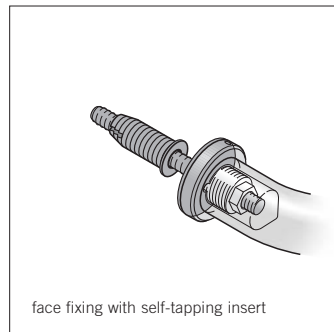
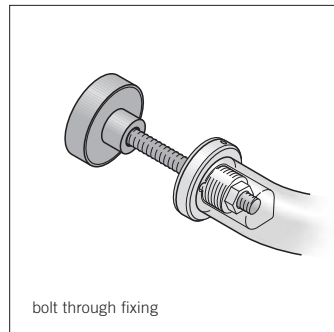
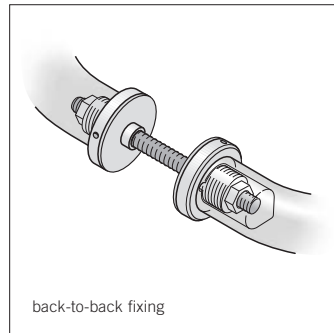

Fixing scenarios

Pull handles can be either face or through-fixed to doors made of the most diverse of materials. In the case of through-fixing, either a pair of pulls or a single handle can be fitted. There are three conceivable fixing options – “back-to-back fixing”, “bolt through fixing” and “face fixing with self-tapping insert”.

As regards the issue of face fixing versus bolt through fixing, FSB wishes to point out that, on account of the threaded-insert fastening technique deployed by FSB, face fixing is both aesthetically pleasing and sufficiently durable as a rule. This needs to be qualified, however, in the case of heavy-duty applications: here, we definitely recommend bolt through-fixing, which ensures that the furniture remains fit for use even after years of heavy treatment, since the forces involved are absorbed on both sides of the door.

Safety clearance (S)

When fitting a pull handle to the closing face of a door, a safety clearance needs to be allowed for between the handle, stile and jamb. The assembly scenario is made more readily comprehensible by the following sketch.

Ideally, safety clearances as recommended by FSB should be adhered to. Nevertheless, conditions at the point of assembly are crucial.

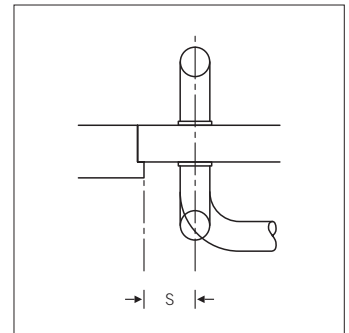

Oval
Pull Handles

6533 37

- Bronze
- Aluminium
- Stainless steel

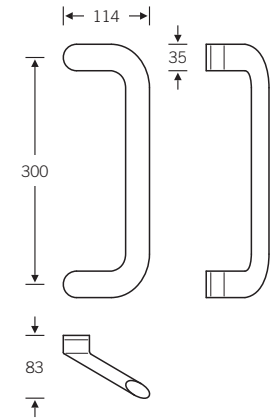

For detailed information on
fixing, please turn to Page 37ff.

6534 37

- Bronze
- Aluminium
- Stainless steel

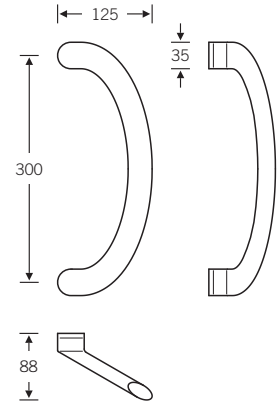

For detailed information on fixing, please turn to Page 37ff.

6535 37

- Bronze
- Aluminium
- Stainless steel

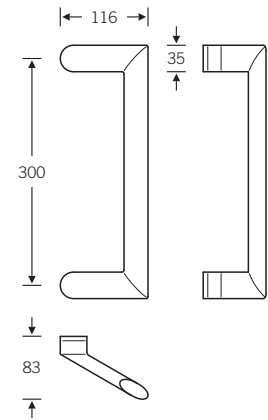

For detailed information on fixing, please turn to Page 37ff.

6538 37

- Bronze
- Stainless steel

Pull handle 6538 37 is related visually to FSB 6535 37. Its 450 mm A Dimension makes it easy to integrate the latching area.

A Dimensions to 1400 mm possible

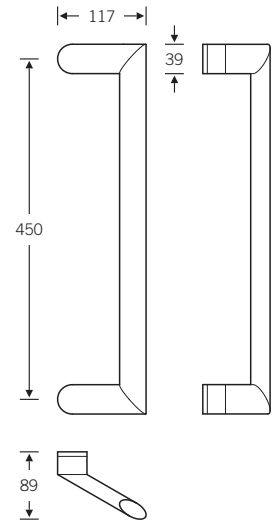

For detailed information on fixing, please turn to Page 37ff.

6536

- Bronze
- Aluminium
- Stainless steel

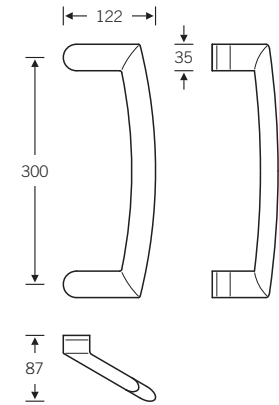

For detailed information on fixing, please turn to Page 37ff.

6537

- Bronze
- Stainless steel

Pull handle 6537 is related visually to FSB 6536. Its 450 mm A Dimension makes it easy to integrate the latching area.

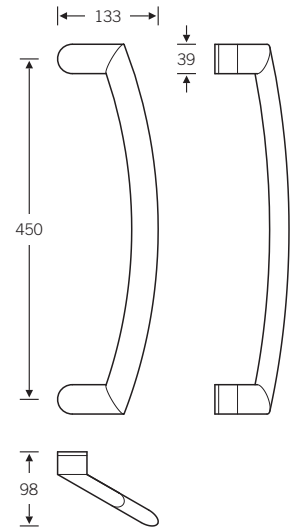

For detailed information on fixing, please turn to Page 37ff.

- Bronze
- Stainless steel

Tube 28 x 40 x 1.5 mm
A Dimensions 1000 – 2100 mm

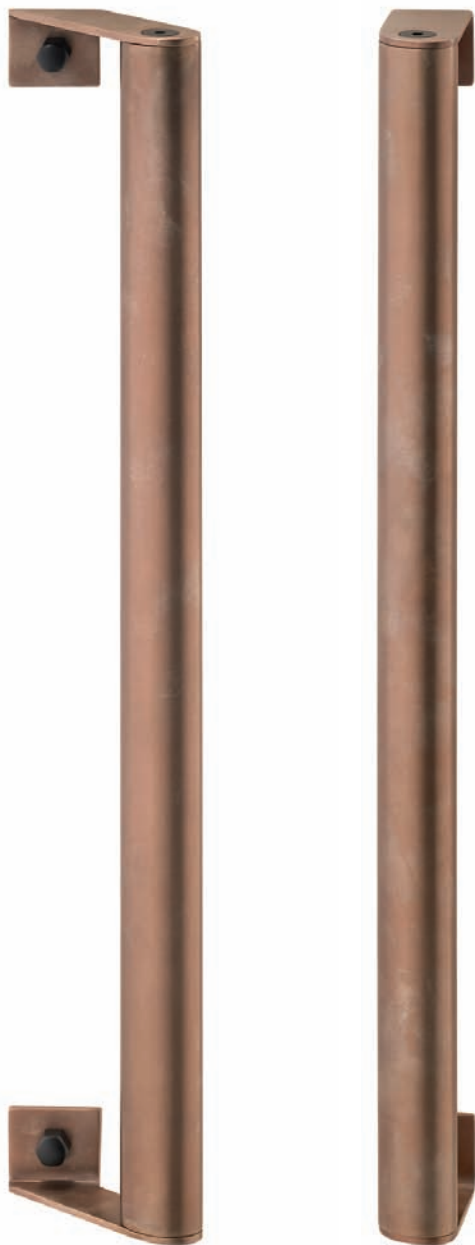

Welded pulls in the 6524 series juxtapose venerable bronze with an absolutely minimalist formal vocabulary. They are produced exclusively to order.

The ordering process involves selecting the combination of brackets desired from the illustrations below and citing the appropriate code numbers (e.g. 6524 4545). It is also necessary to indicate the A dimension, which defines the fixing distance from the centre of the borehole for one bracket to the centre of the borehole for the other ($A \text{ dimension} + 32 \text{ mm} = \text{tube length}$). When using elements of the ht Oval kit, attention needs to be paid to structural specifications and conditions locally. This grip-focus product series is no substitute for gym bars, neither should it be used as a safety rail at openings in buildings. For detailed information on fixing, please turn to Page 37ff.

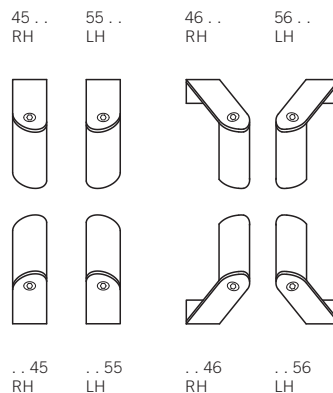
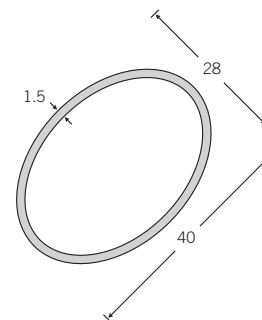

Round 6522

- Bronze
- Stainless steel

Tube Ø 35 x 2.5 mm
A Dimensions 1000 – 2100 mm

Welded pulls in the 6522 series juxtapose venerable bronze with an absolutely minimalist formal vocabulary. They are produced exclusively to order.

The ordering process involves selecting the combination of brackets desired from the illustrations below and citing the appropriate code numbers (e.g. 6522 5656). It is also necessary to indicate the A dimension, which defines the fixing distance from the centre of the borehole for one bracket to the centre of the borehole for the other (A dimension + 32 mm = tube length). When using elements of the ht Oval kit, attention needs to be paid to structural specifications and conditions locally. This grip-focus product series is no substitute for gym bars, neither should it be used as a safety rail at openings in buildings. For detailed information on fixing, please turn to Page 37ff.

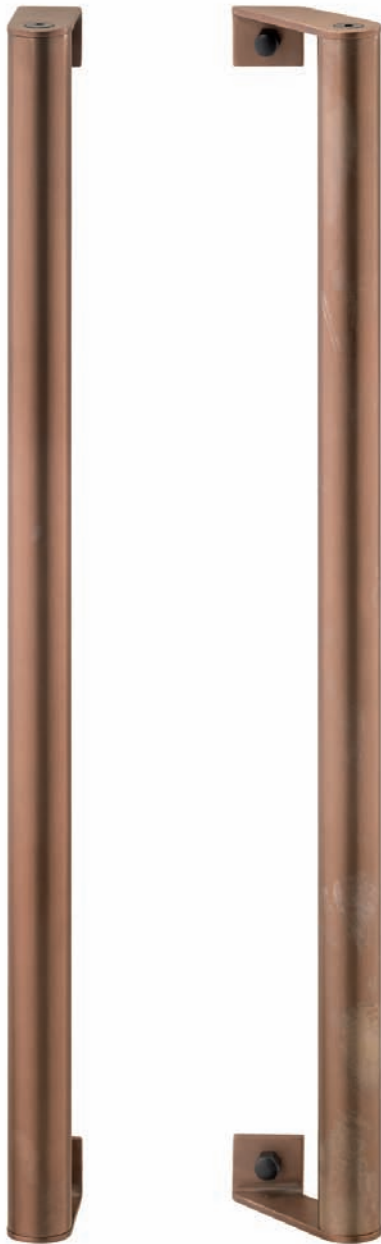
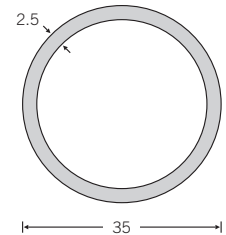

45 . .



. . 45

46 . .
RH



. . 46
RH

56 . .
LH

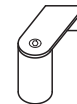

. . 56
LH

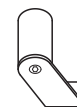

Round
Pull Handles

6506 ..

- Bronze
- Aluminium
- Stainless steel

65 RH | 75 LH
Ø 35 mm

Shown here: RH, outside

M8 fixing
Safety clearance S = 47 mm

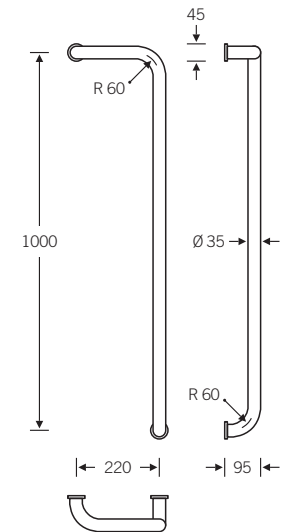
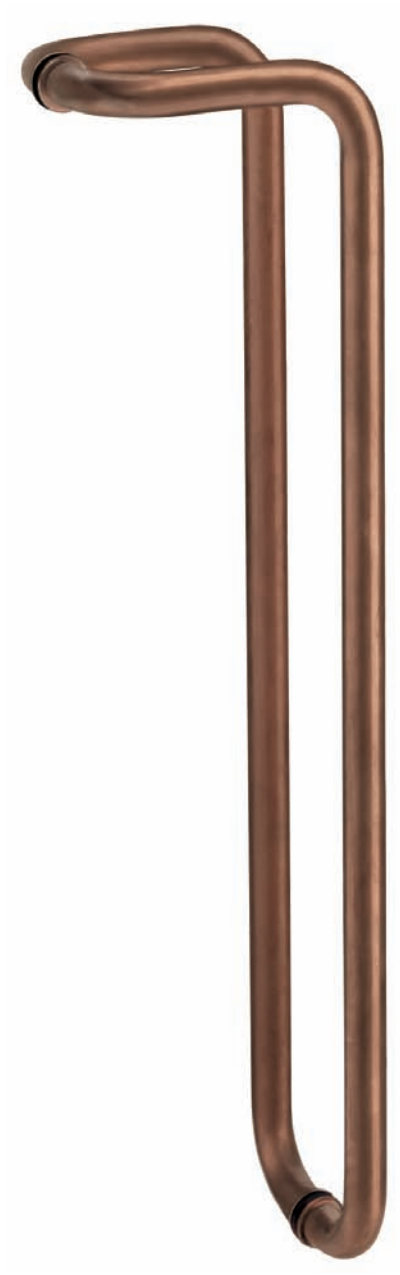

For detailed information on
fixing, please turn to Page 37ff.

6507 ..

- Bronze
- Aluminium
- Stainless steel

65 RH | 75 LH
Ø 35 mm

Shown here: RH, outside

M8 fixing
Safety clearance S = 47 mm

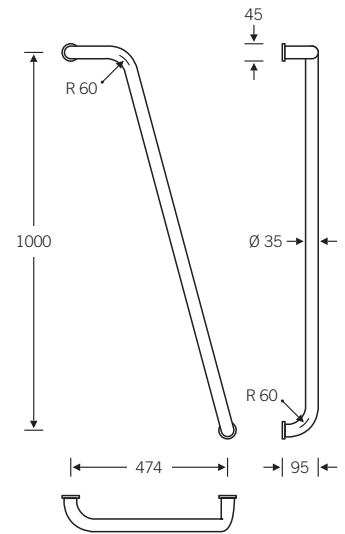
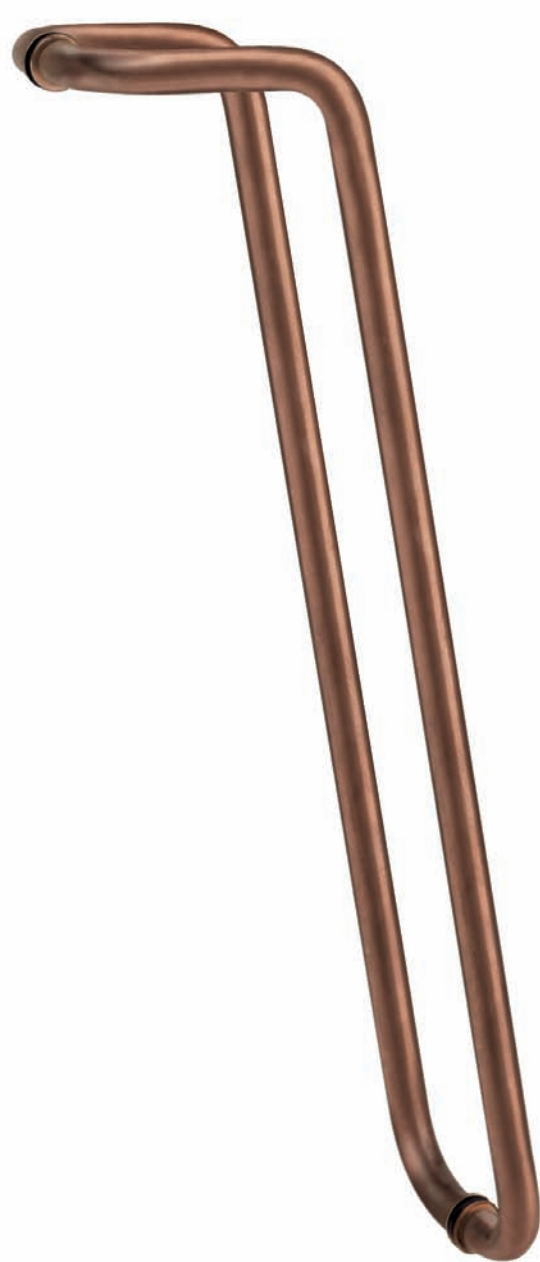

For detailed information on
fixing, please turn to Page 37ff.

6681

- Bronze
- Stainless steel

Ø 30 mm

Standard length 400 mm (also in custom lengths, max. distance between brackets 1200 mm)

M8 fixing
Safety clearance S = 38 mm

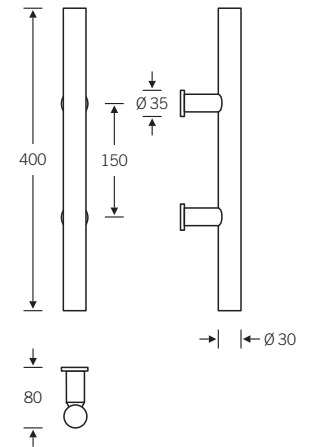

For detailed information on fixing, please turn to Page 37ff.

6669 38

6669 99

- Bronze
(6669 38 and 6669 99 only,
custom lengths to 1200 mm)
- Stainless steel

M8 fixing

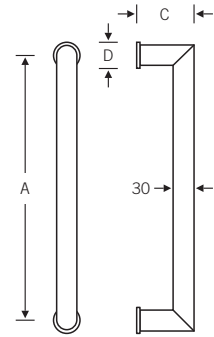
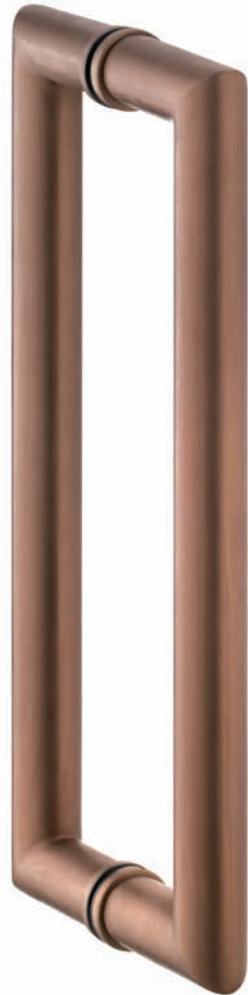

Order code A/C/D/S

6669 38 350/80/35/55
6669 99 351-1200/80/35/55

S Safety clearance

For detailed information on
fixing, please turn to Page 37ff.

6602 38

- Bronze
- Aluminium
- Alu + Colour
- Stainless steel
- Brass

Fixing $\varnothing \geq 25$ mm M8
Safety clearance S = 51 mm

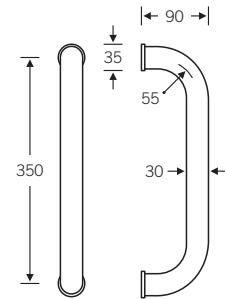
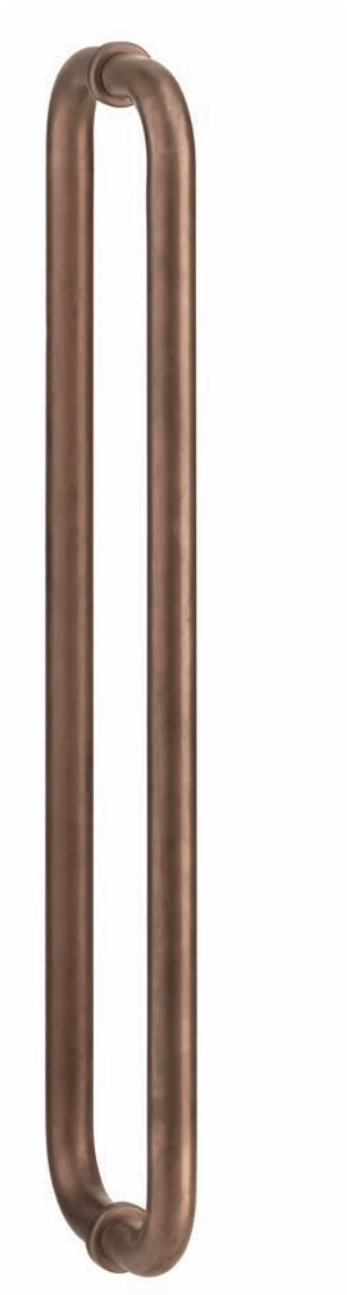

For detailed information on
fixing, please turn to Page 37ff.

6683 38

- Bronze
- Aluminium
- Alu + Colour
- Stainless steel
- Brass

Fixing $\varnothing \geq 25$ mm M8
Safety clearance S = 43 mm

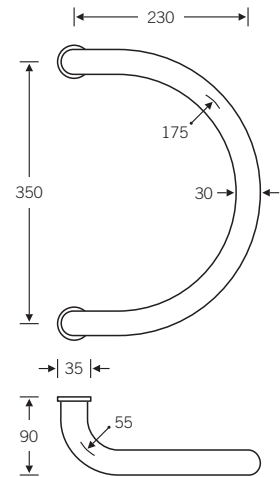

For detailed information on
fixing, please turn to Page 37ff.

Doorknobs

2302 ..



- Bronze (X = 72 mm)
- Aluminium (X = 77 mm)
- AluGrey (X = 77 mm)
- Stainless steel (X = 73 mm)
- Brass (X = 72 mm)

05 face fixing
06 back-to-back fixing
fixing centres 38 mm

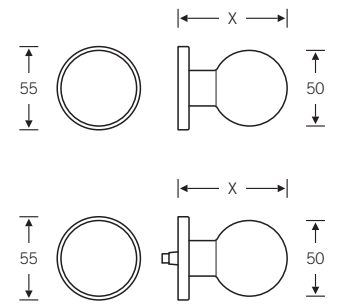

2329 ..



- Bronze ($\varnothing = 50$ mm)
- Aluminium ($\varnothing = 50$ mm)
- AluGrey ($\varnothing = 50$ mm)
- Stainless steel ($\varnothing = 55$ mm)

05 face fixing
06 back-to-back fixing
fixing centres 38 mm

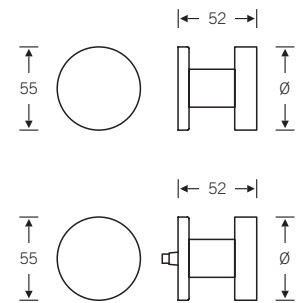

2346 06



- Bronze
- Aluminium
- AluGrey
- Stainless steel

back-to-back fixing
fixing centres 38 mm

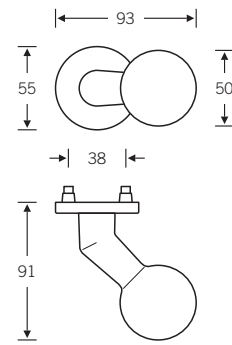

2309 06



- Bronze
- Aluminium
- AluGrey
- Stainless steel

back-to-back fixing
fixing centres 38 mm

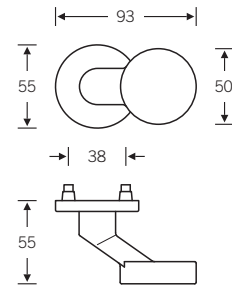

Handle and Rose Assemblies

Handle and rose assemblies with rugged bases for face fixing to main entrance doors. The half-spindles involved in their assembly, FSB 0115 and 0116 respectively, are to be found on Page 42.

7000 0004



- Bronze
- Aluminium
- Stainless steel

10 mm square hole

Model FSB 1023

7000 0347



- Bronze
- Aluminium
- AluGrey
- Stainless steel

10 mm square hole

Model FSB 1015

7000 0348



- Bronze
- Aluminium
- AluGrey
- Stainless steel

8 mm square hole

Model FSB 1163



7395 1...



- Bronze
- Aluminium
- Alu + Colour
- AluGrey
- Stainless steel
- Brass

To suit cylinder projections (CP) as per Table

Order code Ø / Hight / CP

.... 1010	61.5 / 12.5 / 6.5
.... 1110	62.3 / 14.5 / 8.5
.... 1210	63.0 / 16.5 / 10.5

Armoured Roses

Tested and certificated to DIN 18 257 ES 1, DIN EN 1906 Security Class 2 (cf. Page 36), Reg. No. 3V06

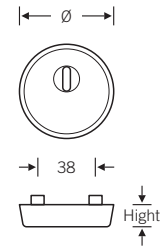

7395 0...



- Bronze
- Aluminium
- Alu + Colour
- AluGrey
- Stainless steel
- Brass

To suit cylinder projections (CP) as per Table

Order code Ø / Hight / CP*

.... 0010	61.5 / 12,5 / 6.5
.... 0110	62.3 / 14.5 / 8.5
.... 0210	63.0 / 16.5 / 10.5

Tested and certificated to DIN 18 257 ES 1, DIN EN 1906 Security Class 2 (cf. Page 36), Reg. No. 3V06

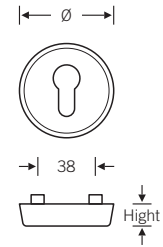

* recommended cylinder projection ±1.5 mm

Flush Armoured Roses



Our range of flush fitting hardware opens up exclusive design perspectives. Detailed information on our new flush armoured roses and other products of similar thrust is obtainable at www.fsb.de

7396 1010 7396 2010

- Bronze
- Aluminium
- AluGrey
- Stainless steel
- Brass

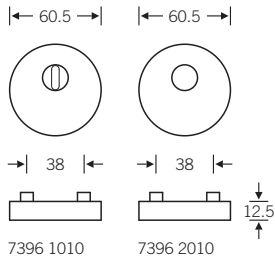

Matching inside rose:
FSB 1735

Both armoured roses have been tested and certificated to DIN 18 257 ES 1, DIN EN 1906 Security Class 2 (cf. Page 36), Reg. No. 3V06

FSB has defined new standards with its flush hardware: supple with AGL® or FS bearings and in all FSB materials, this hardware has become the Number One choice for design-conscious architects and house builders. Our flush armoured roses take the same formal concept forward to the main entrance door. Attention needs to be given when flush recessing armoured roses in the FSB 7396 series not only to the door thickness but also to the distance from the lock centre to the outer edge of the door: in the case of model 7396 1010 the latter needs to be at least 33.5 mm, whereas FSB 7396 2010 contents itself with just 29 mm. Whether the hardware is flush-fitted or not has no impact on its security rating, hence it is also possible to fit armoured roses

with a projection of just a few millimetres or, indeed, to adopt the classic option of “surface mounting” the fitting and thus just as effectively harnessing the armoured rose’s elementally geometrical form. Similarly, the client can dispense with inward flush fixing so as to harmonise the rose with classic hardware on other room doors. Please request solutions of this kind by special order.

Order details:

- door thickness
- version 7396 1010 or 2010
- material/finish
- quantity

3246

- Bronze
- Aluminium
- Alu + Colour
- Stainless steel
- Brass

To suit cylinder projections (CP) of from 8 – 15 mm

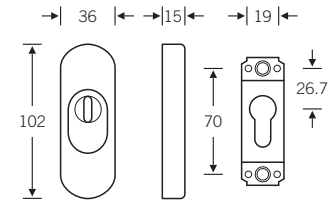



Order details

Standard
Fire Safety

- Design 7375
 Design 7575

Type of furniture

- Entrance door furniture
 Lever handle

Inside version

- Backplate Roses

Security Class backplate set

- S2 11 mm
 S2 15 mm
 S2 - ZA 8 – 16 mm
 S4 - ZA 8 – 16 mm

Security Class rose set

- S2 11 mm
 S2 15 mm
 S2 - ZA 8 – 16 mm

DIN handing of door

- DIN RH,
opening inwards
 DIN LH,
opening inwards

Furniture to suit door
thickness

_____ mm

Lock (EPC) centres

- 72 mm 92 mm
 72 mm

Square spindle

- 8 mm 10 mm
 9 mm

Material/
colour

- | | | |
|---|--------------------------------|---|
| <input checked="" type="checkbox"/> Aluminium | <input type="checkbox"/> 01 | <input type="checkbox"/> _____ |
| <input type="checkbox"/> Alu + Colour | <input type="checkbox"/> white | <input type="checkbox"/> _____ |
| <input type="checkbox"/> Stainless steel | <input type="checkbox"/> 6204 | <input type="checkbox"/> _____ |
| <input checked="" type="checkbox"/> Bronze | <input type="checkbox"/> 7305 | <input type="checkbox"/> 7615 <input type="checkbox"/> 7625 |

(Bronze finishes cf. Page 5)

Version on inside:

Bronze
with FSB 1023

Aluminium
 Alu + Colour
 Stainless steel
with FSB 1107



7376



Order details

Standard
Fire Safety

- Design 7376
 Design 7576

Type of furniture

- Entrance door furniture
 Lever handle

Inside version

- Backplate Roses

Security Class backplate set

- S2 11 mm
 S2 15 mm
 S2 - ZA 8 - 16 mm
 S4 - ZA 8 - 16 mm

Security Class rose set

- S2 11 mm
 S2 15 mm
 S2 - ZA 8 - 16 mm

DIN handing of door

- DIN RH,
opening inwards
 DIN LH,
opening inwards

Furniture to suit door
thickness

_____ mm

Lock (EPC) centres

- 72 mm 92 mm
 72 mm

Square spindle

- 8 mm 10 mm
 9 mm

Material/
colour

- Aluminium
 Alu + Colour
 Stainless steel
 Bronze

- 01 _____
 white _____
 6204 _____
 7305 7615 7625

(Bronze finishes cf. Page 5)

Version on inside:

Bronze
with FSB 1023

Aluminium
 Alu + Colour
 Stainless steel
with FSB 1107



Intercom and Bell-Push Plates

3811

- Bronze
- Stainless steel

Recess to be routed out
W 110 x H 70 x D 30 mm

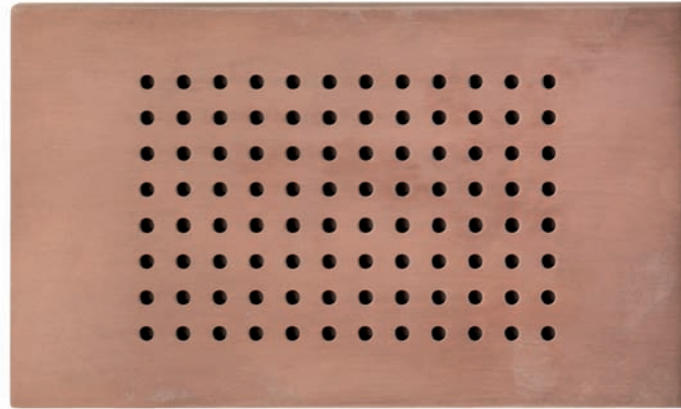
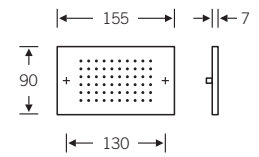

3810

- Bronze
- Stainless steel

Recess to be routed out
W 110 x H 70 x D 30 mm

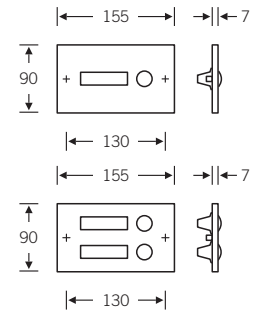

3812

■ Bronze
■ Stainless steel

Recess to be routed out
W 245 x H 70 x D 30 mm

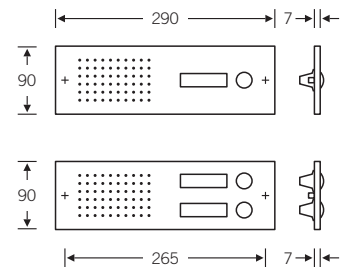
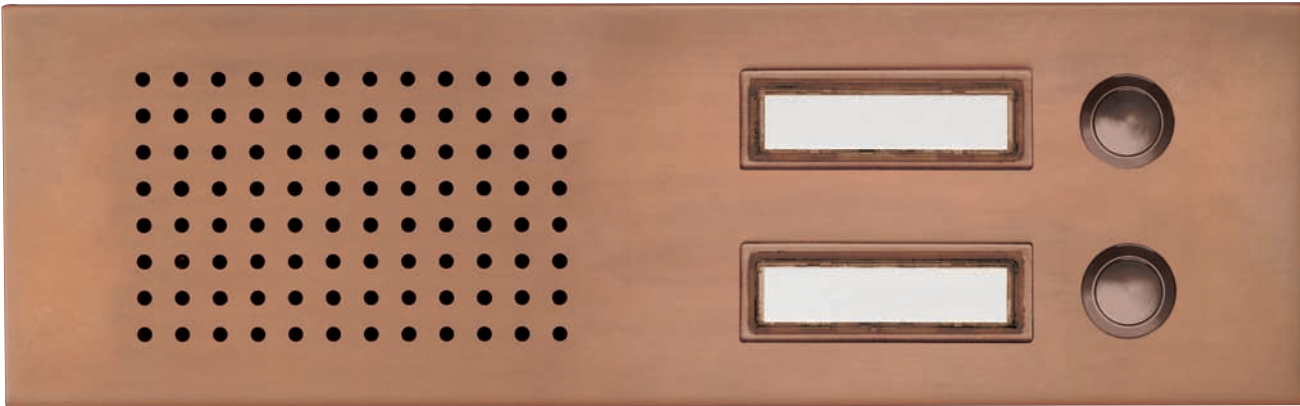

Versions 3810/3812

Interchangeable plastic nameplates

0011 single-section

0012 two-part

0111 single-section for wall mounting

0112 two-part for wall mounting

Screw-on interchangeable nameplates (68 x 20 mm) in Stainless steel and Bronze for custom-engraved names

0021 single-section

0022 two-part

0121 single-section for wall mounting

0122 two-part for wall mounting

Without nameplates for custom-engraved names

0031 single-section

0032 two-part

0131 single-section for wall mounting

0132 two-part for wall mounting

Letter Plate

3808

- Bronze
- Stainless steel

Aperture dim. 230 x 35 mm
Cut-out in door 246 x 60 mm

Concealed fixing either from the inside or through the door tidy.

Versions available:

- Set with black spacer and door tidy for doors 40 – 70 mm or 71 – 100 mm thick.
- Letter plate, no spacer or door tidy, concealed fixing for attachment to wall.

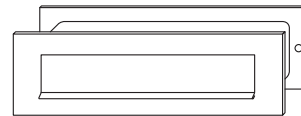

3808 0061 (40 – 70 mm)
3808 0071 (71 – 100 mm)
Set with no nameplate but with spacer and door tidy

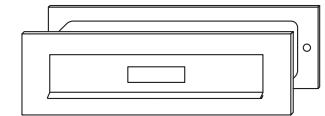

3808 0062 (40 – 70 mm)
3808 0072 (71 – 100 mm)
Set with nameplate, spacer and door tidy

3808 0001
3808 0101 for wall mounting
Letter plate with no nameplate, spacer or door tidy

3808 0002
3808 0102 for wall mounting
Letter plate with nameplate but no spacer or door tidy

3880 ..

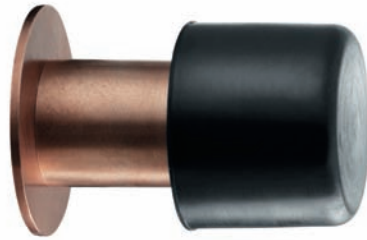

- Bronze
- Aluminium
- Stainless steel

02 length 120 mm
03 length 90 mm
04 length 60 mm

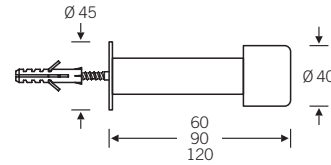

Door Stop

3884



- Bronze
- Aluminium
- Stainless steel
- Brass

3884 10
Black baseplate

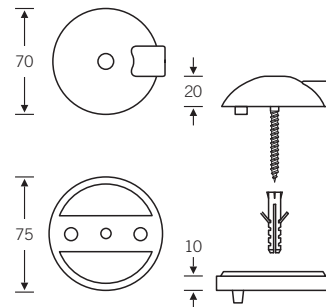

Numbers and Letters

4005 ..

- Bronze
- Stainless steel

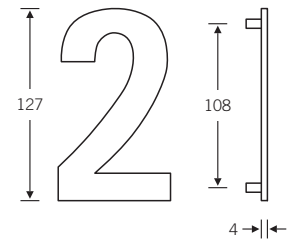

The FSB range of numbers and letters incorporates designs that Otl Aicher recommended for use as a typeface by our company.

Otl Aicher was mainly concerned with ensuring good legibility from a distance. Our characters are manufactured in sheet bronze 4 mm thick. Each character is supplied with fastenings and a fixing template that simultaneously provides an averaged distance between characters. Spacing can of course be determined to suit individual tastes.



Order code:
4005 ..

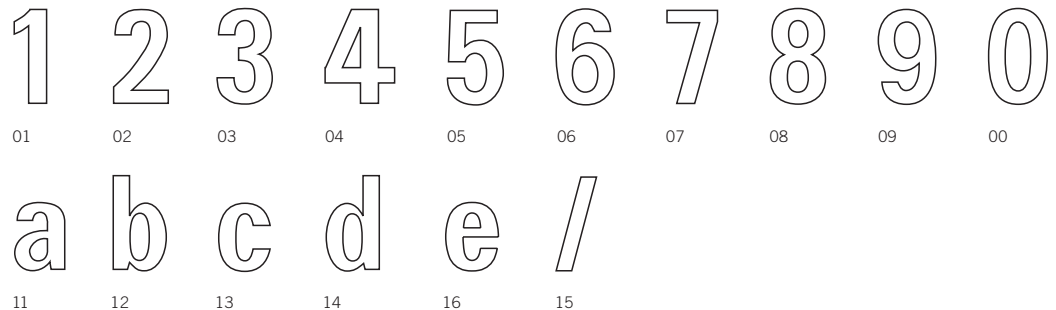

Standards and Security Classes

The following standards provide orientation on the safeguarding of doors and windows:

The German Industrial Standard (DIN) governing burglar-resistant windows, doors and additional barriers (DIN 18 103) and the German Industrial Standard governing “Building hardware; security doorplates concepts and definitions, dimensions, requirements, testing and labeling” (DIN 18 257). In tandem with these, EN 1906 and DIN V ENV 1627–1630 have also been drafted.

FSB security hardware is supplied as standard for the following door thicknesses:

Internal doors	40 – 42 mm
Main entrance doors	67 – 69 mm
FS doors	53 – 57 mm

Besides standard-compliant security fittings, FSB also supplies the following armoured roses of a preventive nature in bronze:

- round armoured roses in an open version 16.5 mm deep
- round armoured roses with anti-tamper protection (ZA), 12.5 mm to 16.5 mm deep
- round armoured roses with anti-tamper protection (ZA), 12.5 mm deep, prepared for flush fitting
- oval armoured roses with anti-tamper protection (ZA), 15 mm deep

These burglar-resistant fittings are designed to deter potential burglars or at the very least to considerably hold them up

The two Security Classes:

Security Class 2 (EN 1906)
open version
(ES-1 K Reg. No. 4X078)
(ES-1 L Reg. No. 4X076)

Strength of backplates 10 kN
max. bending ≤ 5 mm
Tens. force/fastening 15 kN
max. deformation ≤ 5 mm
Drilling resistance 30 s
3-blow chisel test resistance

Security Class 2 (EN 1906)
with anti-tamper protection (ZA)
(ES-1 K-ZA Reg. No. 4X077)
(ES-1 L-ZA Reg. No. 4X079)

Strength 10 kN
max. bending ≤ 5 mm
Tens. force/fastening 15 kN
max. deformation ≤ 5 mm
Drilling resistance 30 s
3-blow chisel test resistance
Strength ZA 10 kN

Security Class 4 (EN 1906)
with anti-tamper protection (ZA)
(ES-3 L-ZA Reg. No. 4X081)

Strength 20 kN
max. bending ≤ 5 mm
Tens. force/fastening 30 kN
max. deformation ≤ 5 mm
Drilling resistance 5 min
12-blow chisel test resistance
Strength ZA 20 kN

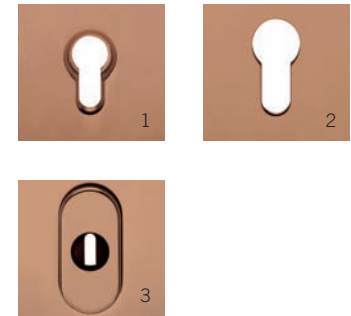

Shown above are the keyways obtainable under the various Security Classes.

Figs. 1 and 2 show open versions (Security Class 2 only), Fig. 3 the version with anti-tamper protection (“ZA” = abbreviation for cylinder cover in German, Security Classes 2 and 4). Cylinder projections of 11 mm (Fig. 1) and 15 mm (Fig. 2) are catered for in the open versions. In the anti-tamper protection version (ZA), cylinder projections of from 8 – 16 mm are catered for.

FSB Fixing Method with Self- Tapping Insert



FSB's threaded insert method constitutes an enhanced practically-minded solution for the concealed face fixing of pull handles to doors made of timber, aluminium and plastic that also guarantees a significantly more efficient absorption of disension forces by the door stile. A single threaded insert 34 mm long serves all door thicknesses and stile types.

The self-tapping thread establishes an ideal connection between the stile and the insert that boasts comparatively low tolerances and ensures an even, efficient application of force.

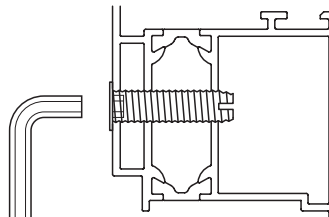

First step

Whether the hole for the FSB threaded insert is drilled mechanically or by hand, a diameter of 12.5 mm (timber doors) or 13 mm (metal and plastic doors) needs to be produced.

Second step

The self-tapping insert is then fitted using a size 8 Allen key. Once the insert lies flush with the stile, the enclosed set screw is screwed home.

Third step

The pull handle is then fitted using via the fixing points.



FSB Fixing Method with Clamping Roses

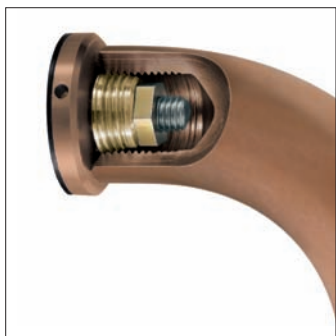

FSB's user-friendly clamping-rose fixing method enables all FSB pulls with a round shank to be tightened fast against the surface of the door. Visible fixing screws are done away with.

The radial play allowed for by FSB ensures the requisite compensatory tolerances during fitting. All pull handles with round shanks are supplied as female parts with an internal left-handed thread 18 mm by 1.5 mm (M8 fastening) or 14 mm by 1.5 mm (M6 fastening). Assembly is as follows.

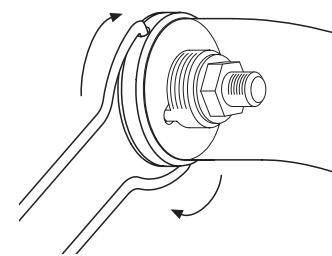
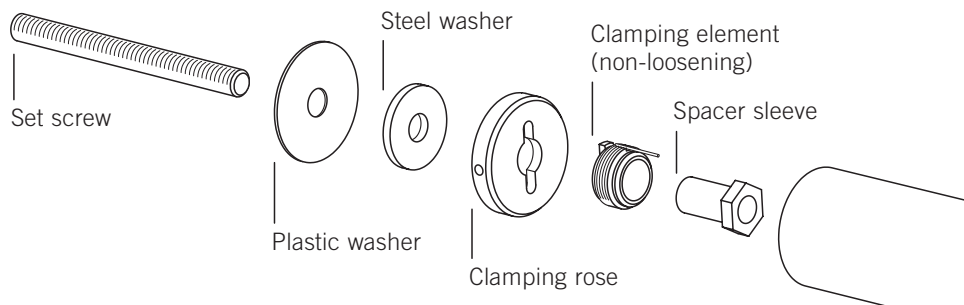

First step

First, the set screw over which the various clamping elements are to be passed is inserted into the door.

Second step

Then detach the clamping elements from the handle ends by turning them anticlockwise. Remove the plastic clip and slip the plastic washer, the steel washer, the clamping rose and the clamping element over the set screw in that order. Using the spacer sleeve, screw the elements together, ensuring

that the clamping rose and clamping element remain free to rotate.

Third step

Position the handle over the fixing points and tighten against the door by alternately turning the clamping roses in a clockwise direction. A turning tool for the FSB clamping rose is supplied with the product.

Drilling Dimensions

Glass doors

Timber doors

Metal doors

Plastic doors

Back-to-back fixing

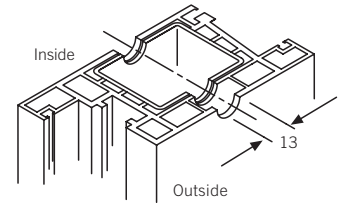
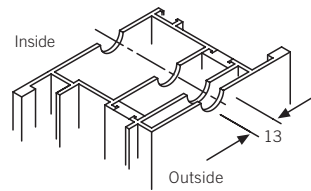
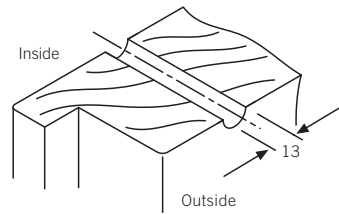
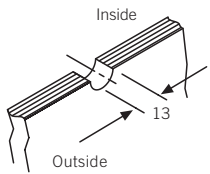

Bolt through fixing

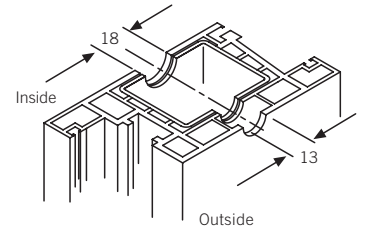
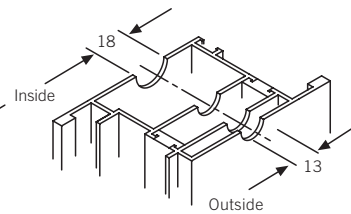
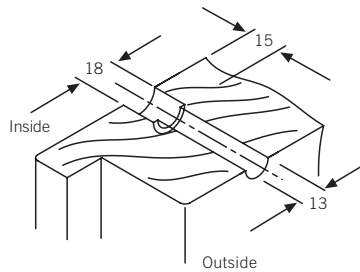
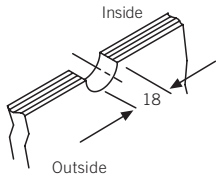

Face fixing with threaded insert

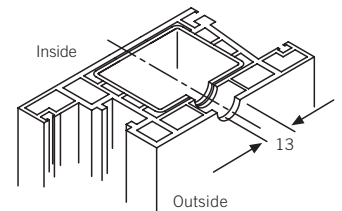
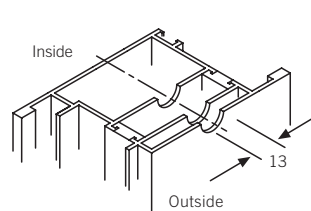
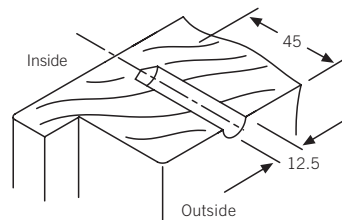

Fixing Details

Round M8 pull handles

6506, 6507, 6533, 6534,
6535, 6536, 6537, 6538,
6602, 6669, 6681, 6683

Fixing method

Fastenings

Order code

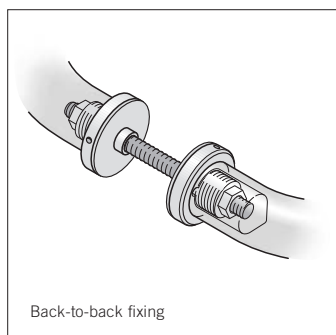

2 M8 set screws

0580 1008

glass door

8 – 10 mm

0580 3035

35 – 54 mm

0580 3055

55 – 74 mm

0580 3075

75 – 94 mm

Drill hole \varnothing 13 mm

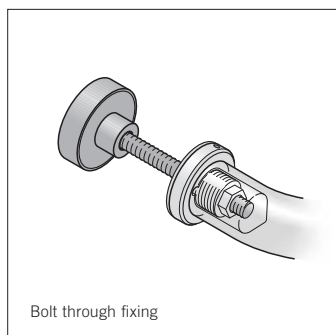

2 M8 set screws

2 fixing nuts with covers

Handle diameter 25/30 mm

Handle diameter 35/40 mm

0580 2308

glass door

8 – 10 mm

0580 2408

glass door

8 – 10 mm

0580 4335

35 – 44 mm

0580 4435

35 – 44 mm

0580 4345

45 – 54 mm

0580 4445

45 – 54 mm

0580 4355

55 – 64 mm

0580 4455

55 – 64 mm

0580 4365

65 – 74 mm

0580 4465

65 – 74 mm

0580 4375

75 – 84 mm

0580 4475

75 – 84 mm

Drill hole \varnothing 13/18 mm,
cf. Page 39

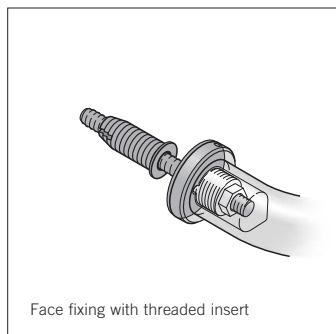

2 M8 set screws

2 self-tapping inserts in
galvanised hardened steel

0580 0335

Dimension X 10 – 30 mm

Plug length 34 mm

Drill hole \varnothing 12.5 mm (timber
doors), \varnothing 13 mm (metal/plastic
doors)

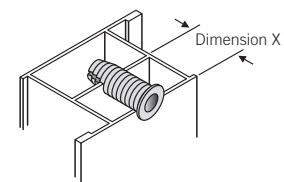

Dimension X = cavity dimension

Pull handle series

ht welded:
6522, 6524

Fixing method

Fastenings

Order code

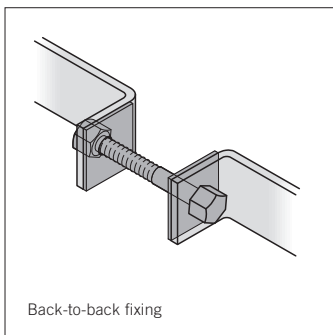

2 M8 set screws	0585 3035	35 – 39 mm
4 stainless steel M8 dome nuts	0585 3040	40 – 44 mm
4 plastic washers	0585 3045	45 – 49 mm
	0585 3050	50 – 54 mm
	0585 3055	55 – 59 mm
	0585 3060	60 – 64 mm
	0585 3065	65 – 69 mm
	0585 3070	70 – 74 mm
	0585 3075	75 – 79 mm
	0585 3080	80 – 84 mm

Drill hole \varnothing 13 mm

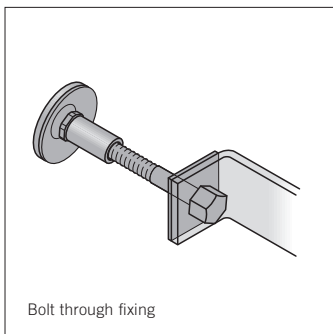

2 M8 set screws	0585 2035	35 – 44 mm
2 stainless steel M8 dome nuts	0585 2045	45 – 54 mm
2 M8 sleeve nuts with stainless steel washers	0585 2055	55 – 64 mm
4 plastic washers	0585 2065	65 – 74 mm
	0585 2075	75 – 84 mm

Drill hole \varnothing 13 mm

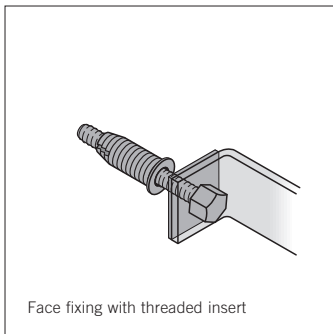

2 M8 set screws	0585 0335	
2 stainless steel M8 dome nuts	Dimension X	10 – 30 mm
2 self-tapping inserts in galvanised hardened steel	Plug length 34 mm	
2 plastic washers		

Drill hole \varnothing 12.5 mm (timber doors), \varnothing 13 mm (metal/plastic doors)

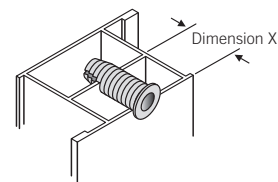

Dimension X = cavity dimension

Half Spindles

0115
0116



FSB half spindles
for face fixing

Dimension X

0115 0810	8 x 60 mm, 20 – 24 mm
0115 0812	8 x 65 mm, 25 – 29 mm
0115 0814	8 x 70 mm, 30 – 34 mm
0115 0816	8 x 75 mm, 35 – 39 mm
0115 0818	8 x 80 mm, 40 – 44 mm
0115 0910	9 x 60 mm, 20 – 24 mm
0115 0912	9 x 65 mm, 25 – 29 mm
0115 0914	9 x 70 mm, 30 – 34 mm
0115 0916	9 x 75 mm, 35 – 39 mm
0115 0918	9 x 80 mm, 40 – 44 mm
0115 1010	10 x 60 mm, 20 – 24 mm
0115 1012	10 x 65 mm, 25 – 29 mm
0115 1014	10 x 70 mm, 30 – 34 mm
0115 1016	10 x 75 mm, 35 – 39 mm
0115 1018	10 x 80 mm, 40 – 44 mm
0116 1012	8/10 x 65 mm, 25 – 29 mm*
0116 1014	8/10 x 70 mm, 30 – 34 mm*
0116 1016	8/10 x 75 mm, 35 – 39 mm*
0116 1018	8/10 x 80 mm, 40 – 44 mm*

* offset, 8 mm handle recess,
10 mm lock follower

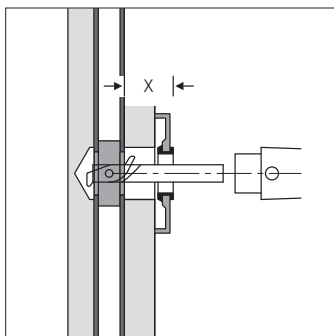



Franz Schneider
Brakel GmbH + Co KG

FSB

Nieheimer Straße 38
33034 Brakel
Germany

Phone +49 5272 608-0
Fax +49 5272 608-300
www.fsb.de · info@fsb.de